

**SONY**

---

# Gigabit Video InterFace

new compact interface for Flat Panel Monitor

VESA P&D Meeting

July 9, 1997

---

## **Outline**

1. Background
  2. Applications
  3. Panel Resolution vs. Data Rate
  4. Block Diagram of Chip set
  5. Features
  6. Summary
-

## Background

Existing interfaces for display monitors are too big and costly to apply to mobile system and future home information appliances.

Standard	Features	Applications
EVC-2 VP&D	Over 30-pin connector Thick cable	W/S High-end P/C Ultra high-resolution monitor
New Interface (GVIF)	Small connector Thin cable	Mobile system Notebook computer Home-use large screen display

---

# Applications

GVIF is suitable for interfacing to...

- 1) External display for mobile system

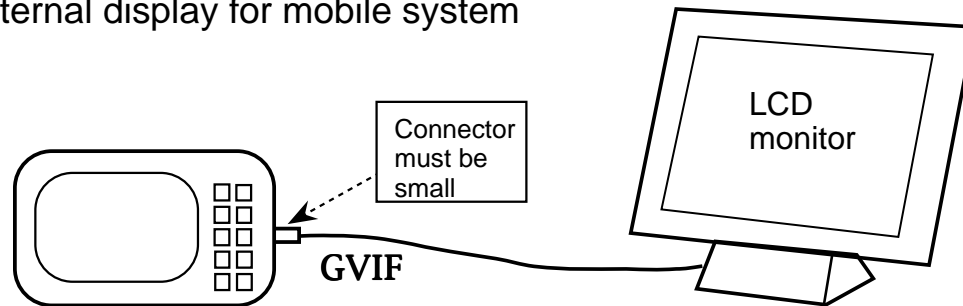

- 2) Desktop monitor for office-use

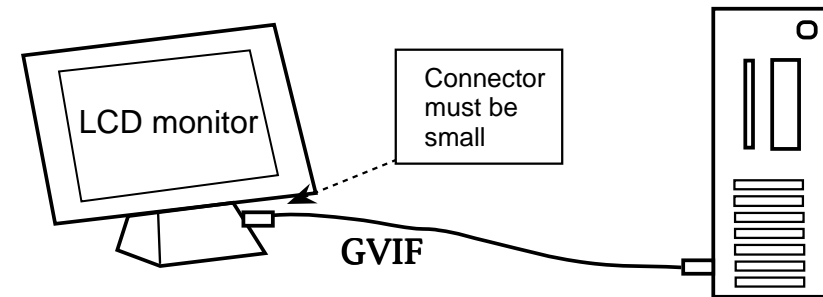

- 3) Home-theater display connected to P/C

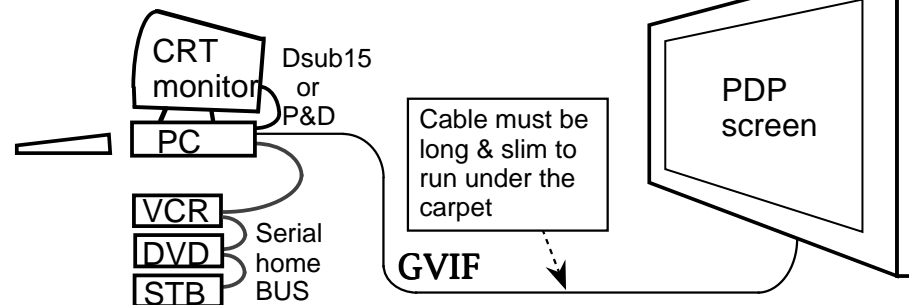

## Panel Resolution vs. Data Rate

GVIF achieves 1.2Gb/s data transmission with BiCMOS or CMOS technology, and 2.0Gb/s with Si Bipolar or GaAs technology.

- A single GVIF fully supports monitors in most use, up to XGA.
- A plural of GVIFs can handle HDTV signal.

	Panel resolution	Dot clock	Serial bit rate	
			18bit color	24bit color
VGA	640x480	25MHz	0.60Gb/s	0.75Gb/s
SVGA	800x600	40MHz	0.96Gb/s	1.20Gb/s
XGA	1024x768	65MHz	1.56Gb/s	1.95Gb/s
SXGA	1280x1024	81MHz	1.94Gb/s	2.43Gb/s
UXGA	1600x1200	118MHz	2.83Gb/s	3.54Gb/s
HDTV	1920x1080	128MHz	3.07Gb/s	3.84Gb/s
?	2000x1500	185MHz	4.44Gb/s	5.55Gb/s

Assumption 60Hz frame rate,  
2.5% blanking (reduced blanking) for SXGA and upper class resolution

---

## Block Diagram of Chip set

GVIF implements bit-serial transmission with currently available technologies

- Serializer/Deserializer
- PLL for transmission clock recovery
- Automatic equalizer
- Channel coding and Decoding

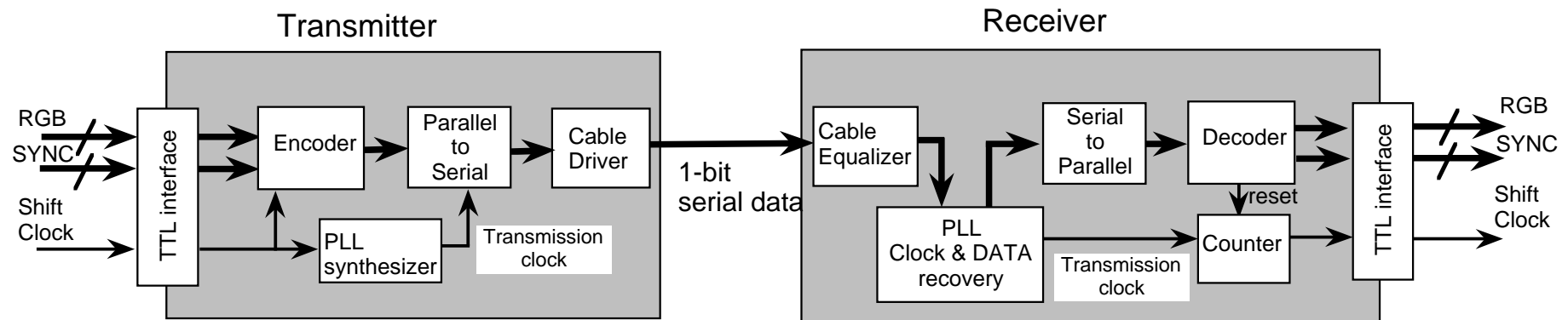

## Features

- Small connector and inexpensive Twinax cable
- Drivability of long cable more than 10 meters
- Low EMI (FCC B-class) with a swing voltage of 400mv(p-p)

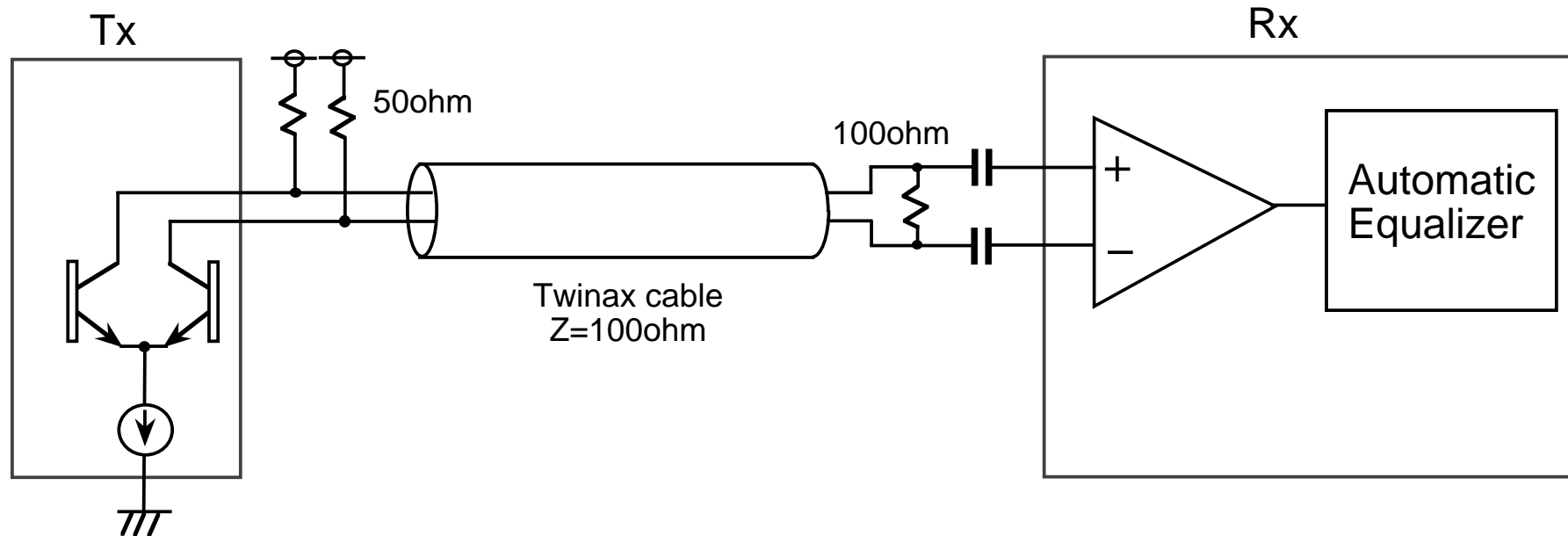

## Summary

GVIF offers a substantially small and simple solution to connect information appliances to advanced Flat Panel Display Monitors.

Test samples of the first chip set are available.

### Issues

- Low power consumption
  - miniature, reliable connector
-